

FRENCH FITNESS

FFV-FIDOBP / FFN-FIDOBP

FRENCH FITNESS VENICE / NEWPORT
3 WAY FLAT INCLINE DECLINE OLYMPIC BENCH

ASSEMBLY MANUAL



FEATURES

- Paint Color: Silver / Black
- Vinyl Color: Black
- Frame undergoes electrostatic spraying, including three coatings and two baking stages
- 10 adjustable incline/flat/decline positions
- Adjustable angle -15 to 30 degree with 5-degree increment
 - Lower Chest: -15°, -10°, -5°
 - Middle Chest: 0°, 5°, 10°
 - Upper Chest: 15°, 20°, 25°, 30°
- Seat pad moves in a straight position along the back pad
- 16 unique horizontal positions with a 337mm range of adjustments
- Rear extension with non-skid spotter platform
- Four (4) catch bars
- Built-in four (4) weight horns
- High-density PU leather cushions to provide exceptional comfort.
- Dual footrest tubes

TECH SPECS

- Steel Tube: 50mm x 100mm x 2.5mm rectangle tube / 50mm x 75mm x 2.5mm rectangle tube
- Max Load (Bar hook): 606.2 lbs (275 KG)
- Max Load (Seat): 771.6 lbs (350 KG)
- Max Load: (Weight Horn): 330.6 (150 KG)
- Weight Horn Diameter: 2" (50mm)
- Weight Horn Length: 12.5" (320mm)
- Machine Weight: 196.2 lbs (89 KG)
- Machine Dimensions: 95"L 74"W x 56"H (L:2410mm, W:1880mm, H:1420mm)

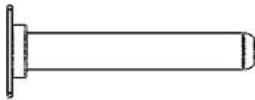
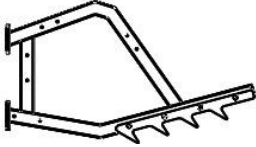
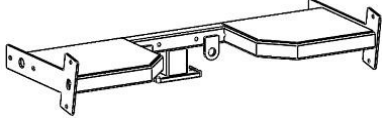
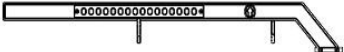
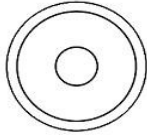
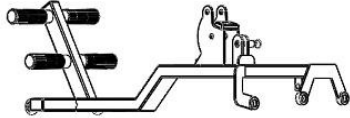
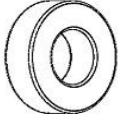

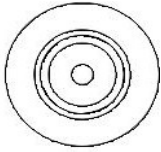

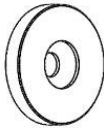
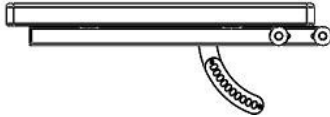

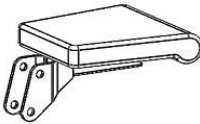
WARRANTY

10 Years Parts, 1 Year Labor (Commercial)

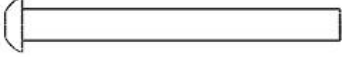
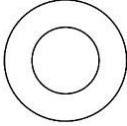

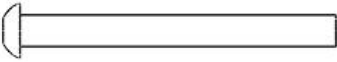
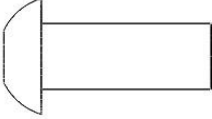

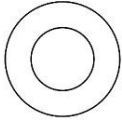

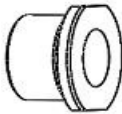

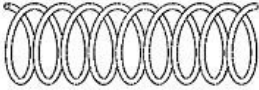
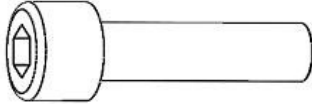


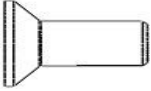
TABLE OF CONTENTS

PARTS LIST (INDIVIDUALLY PACKAGED)	4
BLISTER PACK LIST	5
ASSEMBLY STEPS	6

PARTS LIST (INDIVIDUALLY PACKAGED)

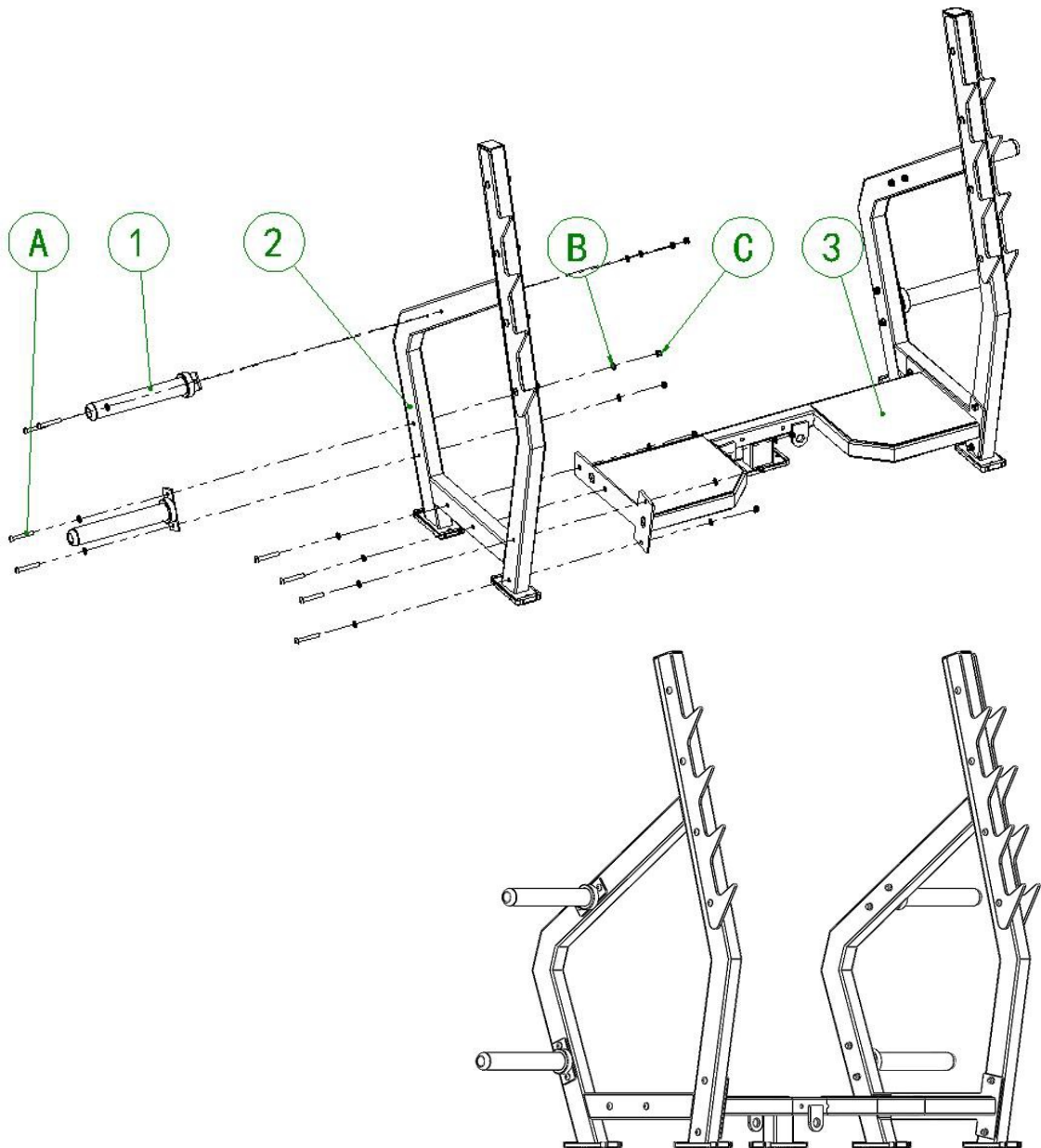
					
NO.1	Barrel welding group*4	NO.2	Side frame set*2	NO.3	Bending group*1
					
NO.9	0100 bottom support group*1	NO.12	0211 small round baffle*6	NO.13	0400 sliding group*1
					
NO.14	5065 Round cushion*6	NO.15	0003 optical axis*3	NO.25	PU wheel set (Q102)*2
					
NO.26	0800 gear adjustment group*1	NO.28	2004 Aluminum flat end cap*8	NO.30	0500 backrest group*1
					
NO.31	2004 Galvanized shaft*4	NO.37	0600 Cushion group*1		

BLISTER PACK LIST

					
A	M10*70 flat head screw*18	B	Ø10 Gasket*54	C	M10 lock nut*26
					
D	M10*75 round head screw*8	F	M10*20 flat head screw*8	I	M8*45 round head screw*2
					
J	Ø8 gasket*12	K	M8 lock nut*2	L	0137 Nut*1
					
M	0136 gear pull pin shaft*1	N	0305-1 spherical spring*1	O	M5*20 cylinder head screw*1
					
P	M5 lock nut*1	Q	M6*50 cylinder head screw*1	S	M10*20 flat countersunk head screw*8

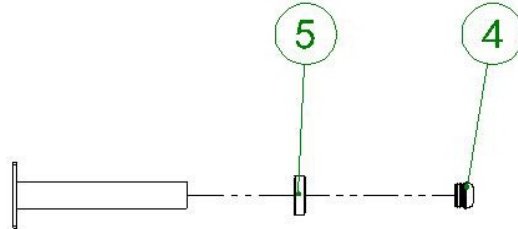
ASSEMBLY STEPS

Step	Item No.	Name	Quantity	Item No.	Name	Quantity
1	NO.1	Barrel welding group	4	A	M10*70 flat head screw	16
	NO.2	Side frame set	2	B	Φ10 Gasket	32
	NO.3	Bending group	1	C	M10 lock nut	16



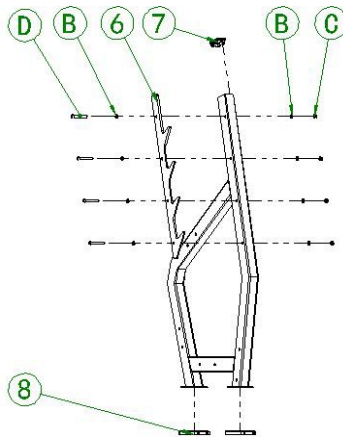
NO.1 Barrel welding group*4

Step	Item No.	Name	Quantity	Item No.	Name	Quantity
	NO.4	0608 Barbell pipe plug	1	NO.5	rubber sleeve	



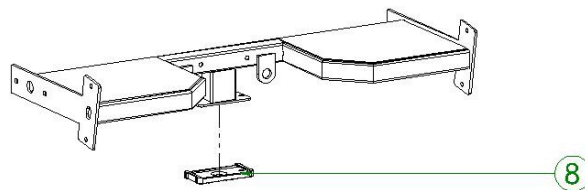
NO.2 Side frame set*2

Step	Item No.	Name	Quantity	Item No.	Name	Quantity
	NO.6	0001 hook plate	1	B	Φ10 Gasket	8
	NO.7	Square tube plug 50*75	1	C	M10 lock nut	4
	NO.8	6010 Foot cover	2	D	M10*75 round head screw	4



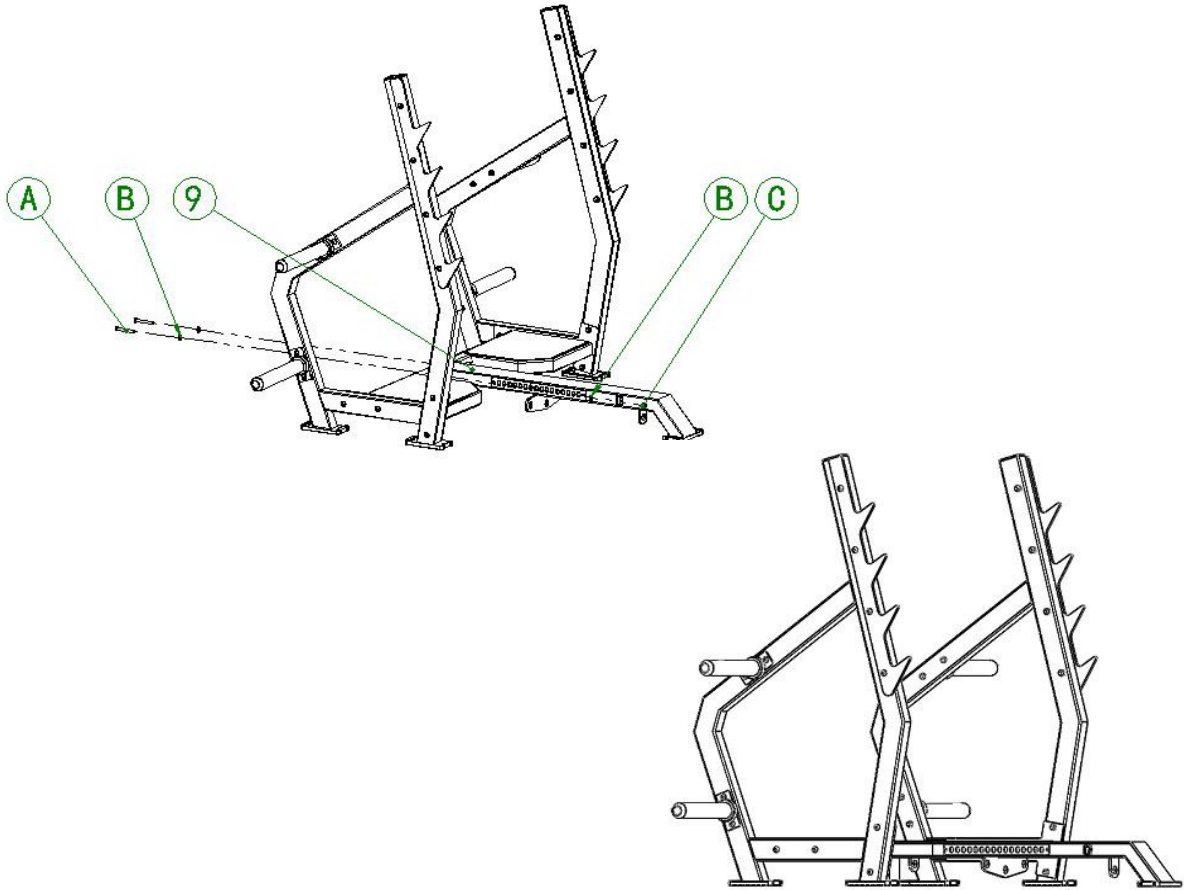
NO.3 Bending group*1

Step	Item No.	Name	Quantity	Item No.	Name	Quantity
	NO.8	6010 Foot cover	1			



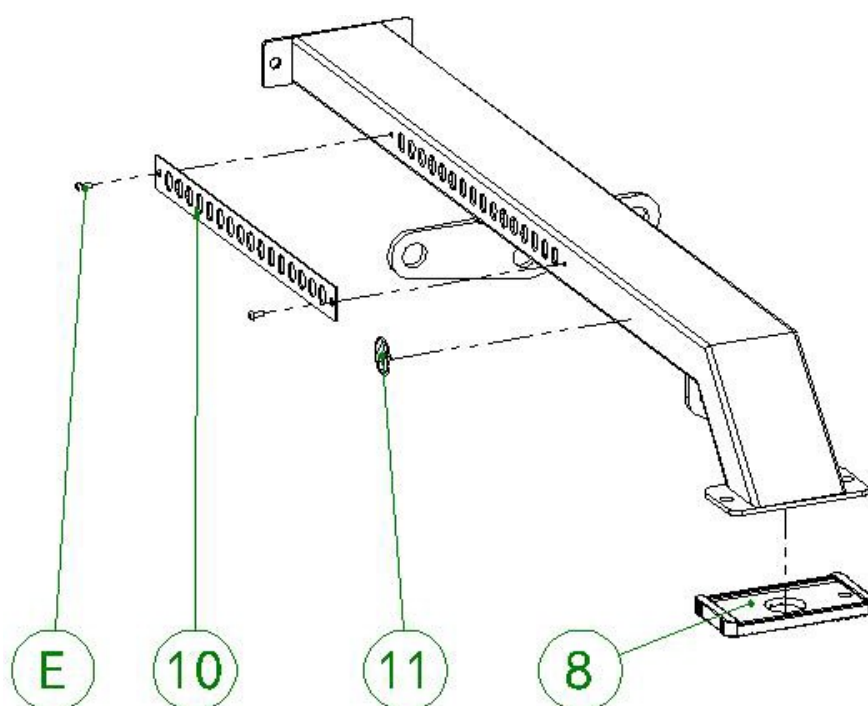
Assembly steps

Step	Item No.	Name	Quantity	Item No.	Name	Quantity
2	NO.9	0100 bottom support group	1	B	Φ10 Gasket	4
	A	M10*70 flat head screw	2	C	M10 lock nut	2



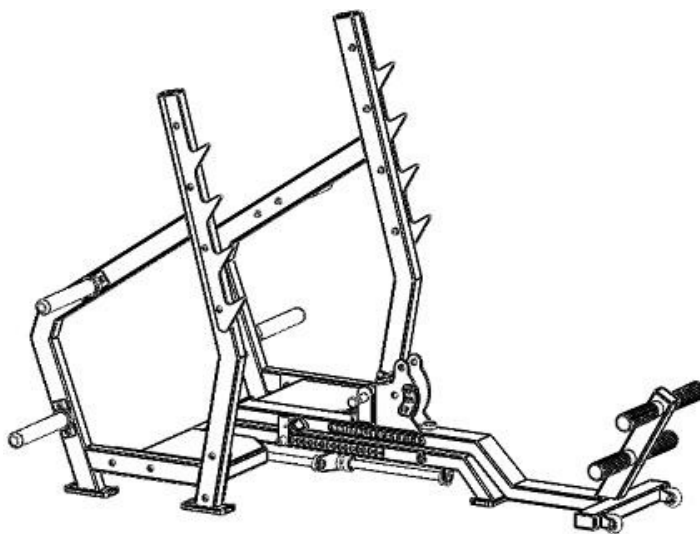
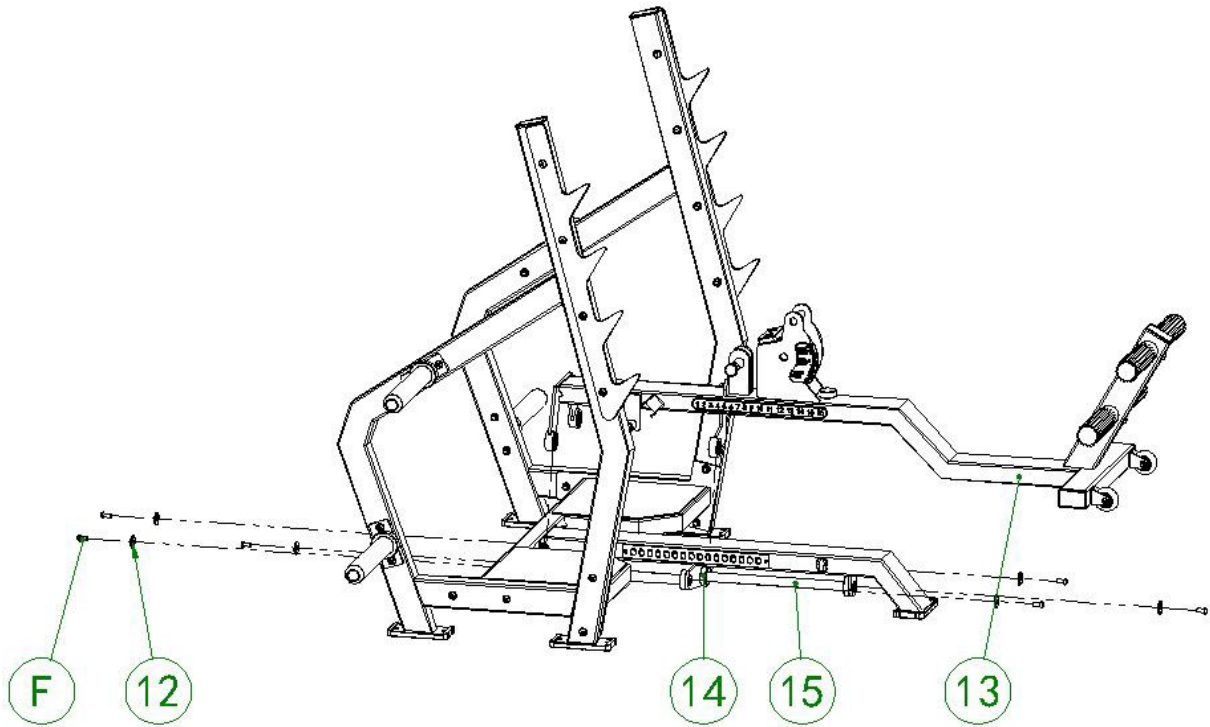
NO.9 bottom support group*1

Step	Item No.	Name	Quantity	Item No.	Name	Quantity
	NO.8	6010 Foot cover	1	E	M5*12 flat head screw	
	NO.10	0004 gear decorative board	1			
	NO.11	5006 gear indicator	1			



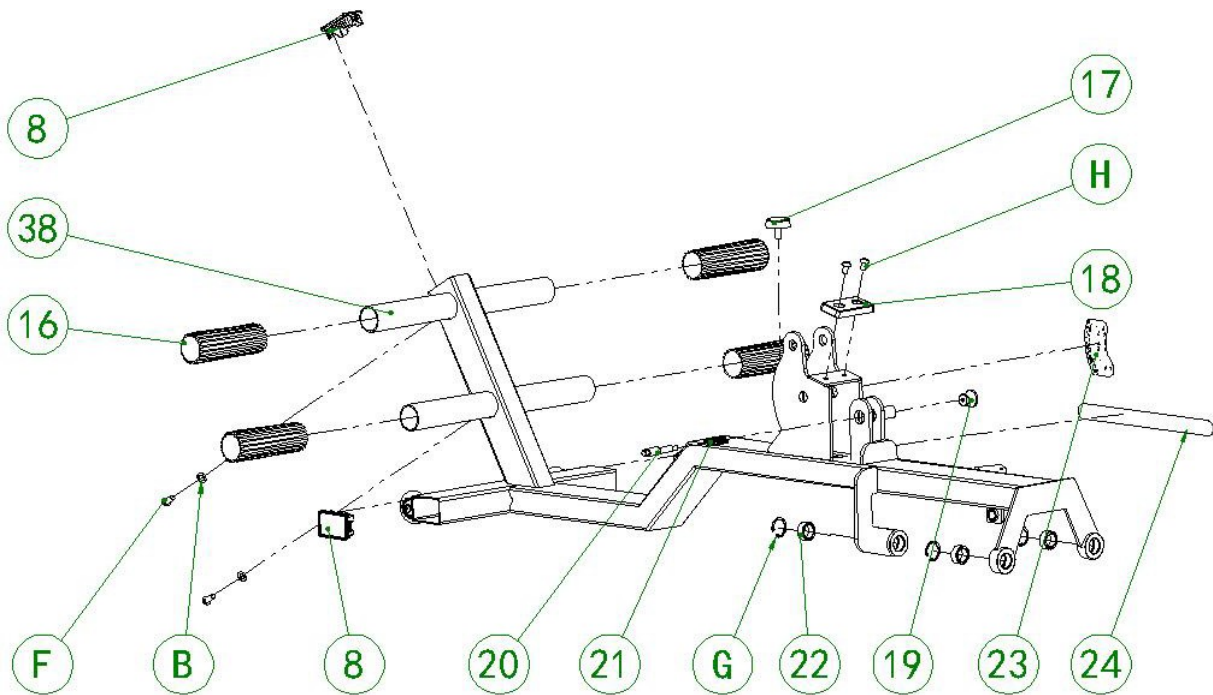
Assembly steps

Step	Item No.	Name	Quantity	Item No.	Name	Quantity
3	NO.12	0211 small round baffle	6	F	M10*20 flat head screw	6
	NO.13	0400 sliding group	1			
	NO.14	5065 Round cushion	6			
	NO.15	0003 optical axis	3			



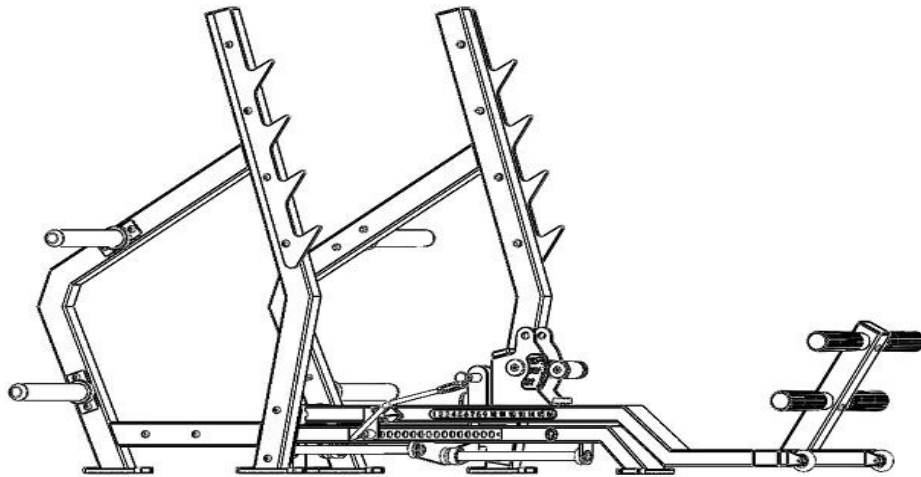
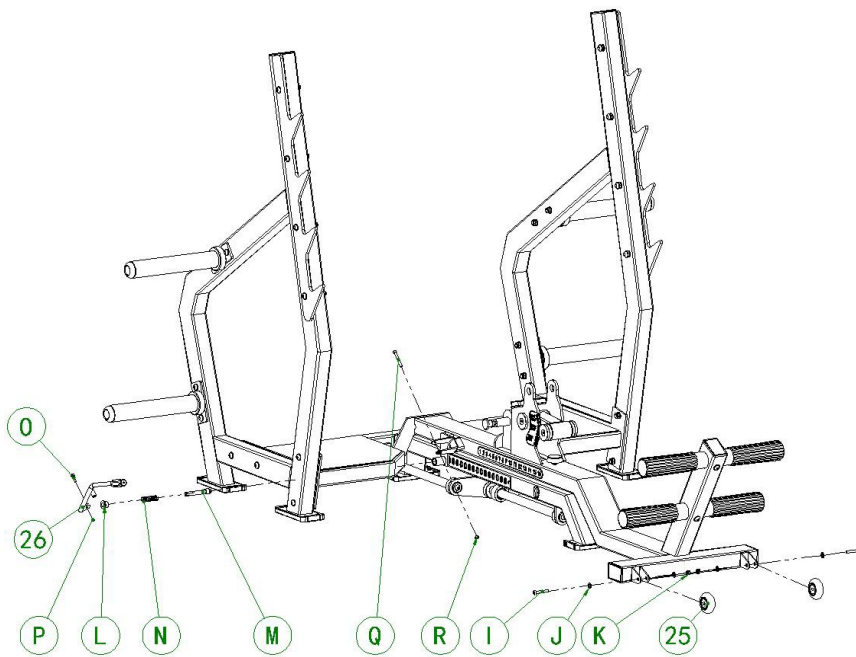
NO.13 sliding group*1

Step	Item No.	Name	Quantity	Item No.	Name	Quantity
	NO.8	Square tube plug 50*75	2	NO.21	spring	1
	NO.16	No. 210 pedal tube pad	4	NO.22	Counterweight inner sliding sleeve	3
	NO.17	038 Shock absorbing positioning block (short)	1	NO.23	Arc gear mark	1
	NO.18	Thin shock pad 15mm	1	NO.24	gear sign	1
	NO.19	Aluminum alloy spring pin	1	G	Φ32 circlip	3
	NO.20	Pin (galvanized)	1	H	M10*16 flat head screw	2
	NO.38	0002 pedal tube	2	B	Φ10 Gasket	2
	F	M10*20 flat head screw	2			



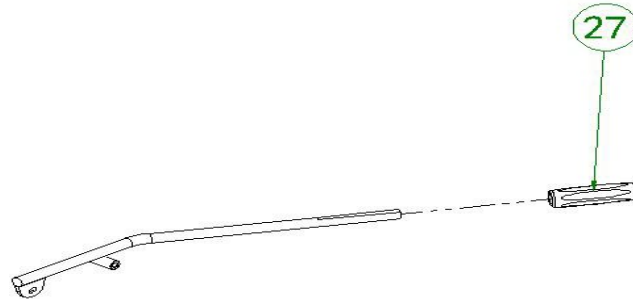
Assembly steps

Step	Item No.	Name	Quantity	Item No.	Name	Quantity
4	NO.25	PU wheel set	2	N	0305-1 spherical spring	1
	NO.26	0800 gear adjustment group	1	O	M5*20 cylinder head screw	1
	J	Φ8 gasket	4	P	M5 lock nut	1
	K	M8 lock nut	2	I	M8*45 round head screw	2
	L	0137 Nut	1	Q	M6*50 cylinder head screw	1
	M	0136 gear pull pin shaft	1	R	M6 lock nut	1



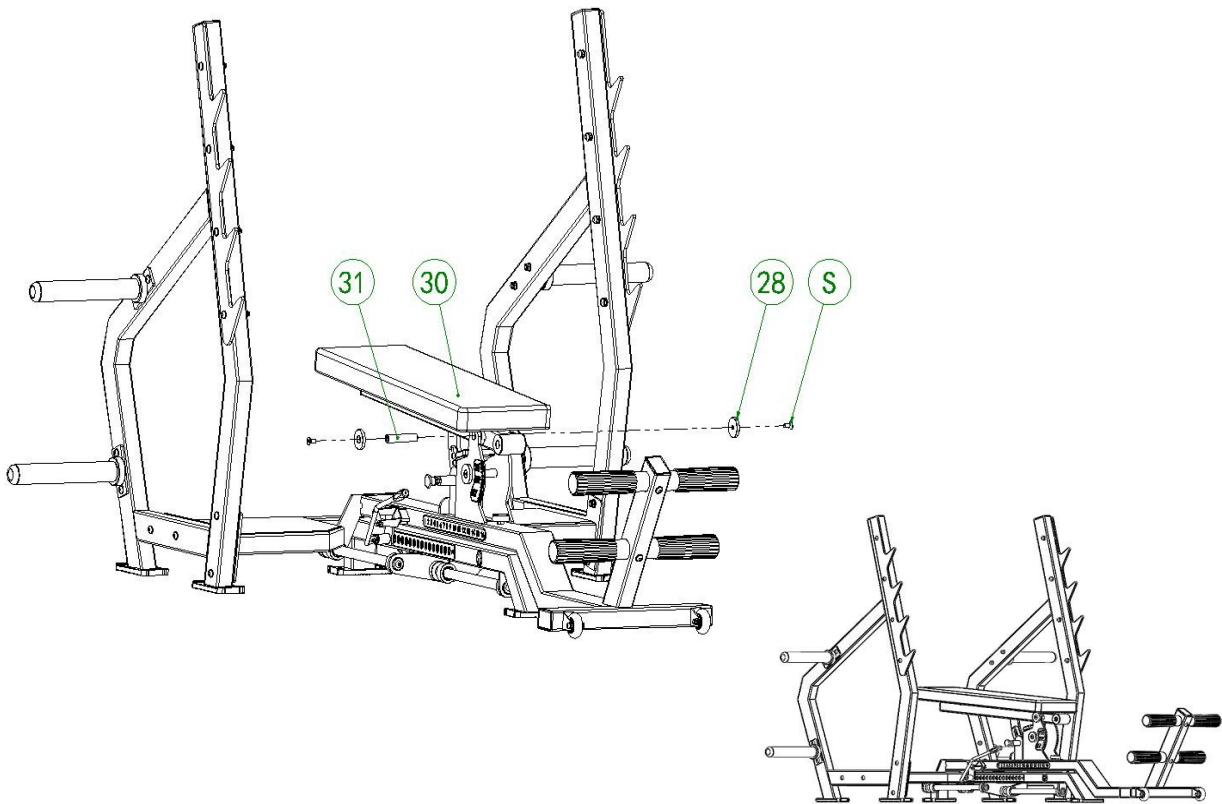
NO.26 gear adjustment group*1

Step	Item No.	Name	Quantity	Item No.	Name	Quantity
	NO.27	small yellow handle	1			



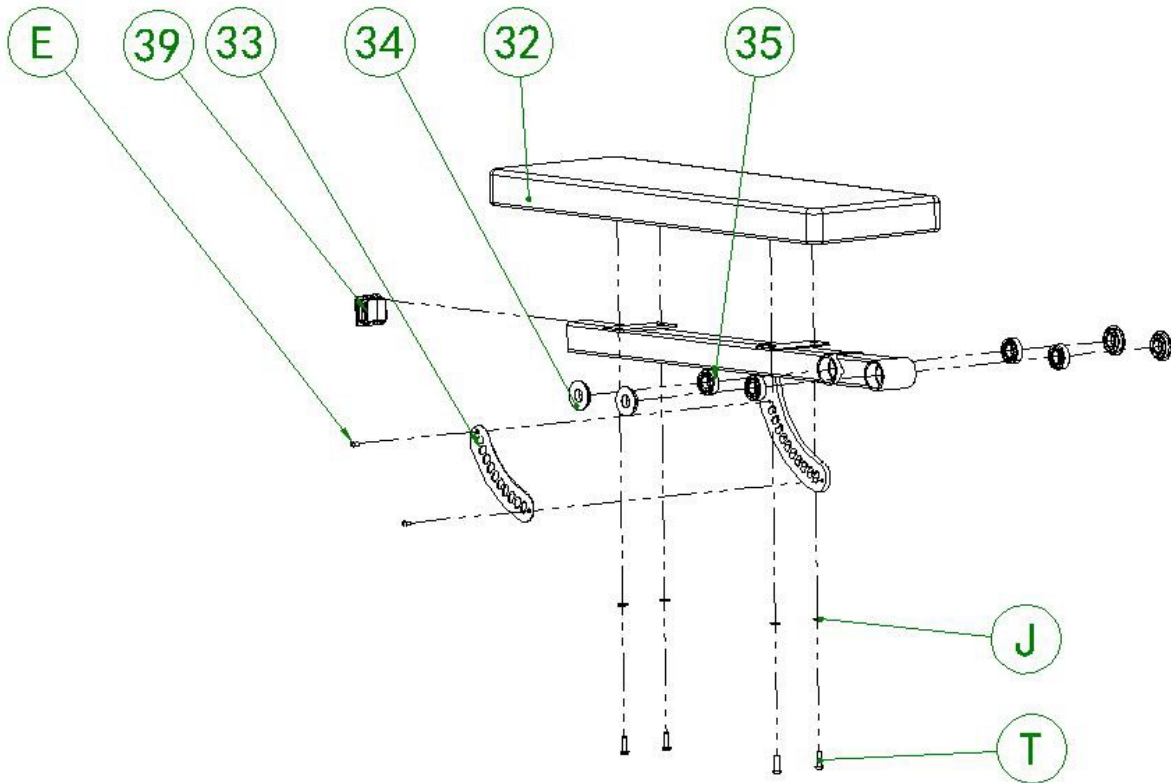
Assembly steps

Step	Item No.	Name	Quantity	Item No.	Name	Quantity
5	NO.28	Aluminum flat end cap	2	S	M10*20 flat countersunk head screw	2
	NO.30	backrest group	1			
	NO.31	Galvanized shaft	1			



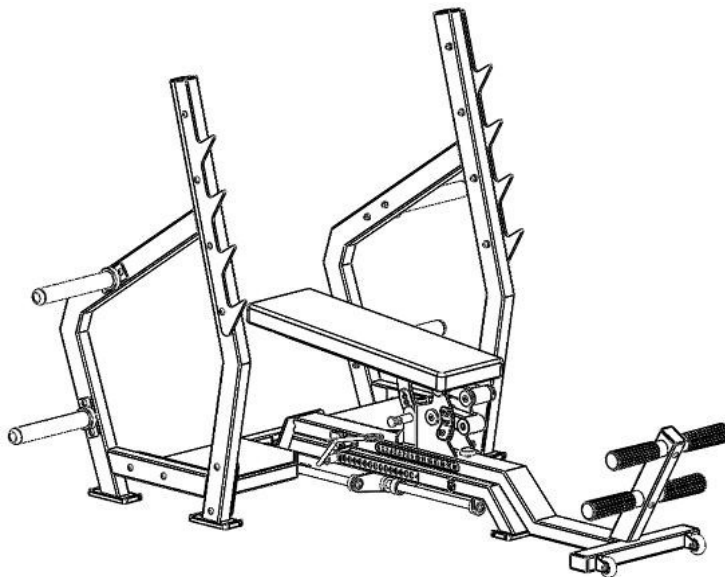
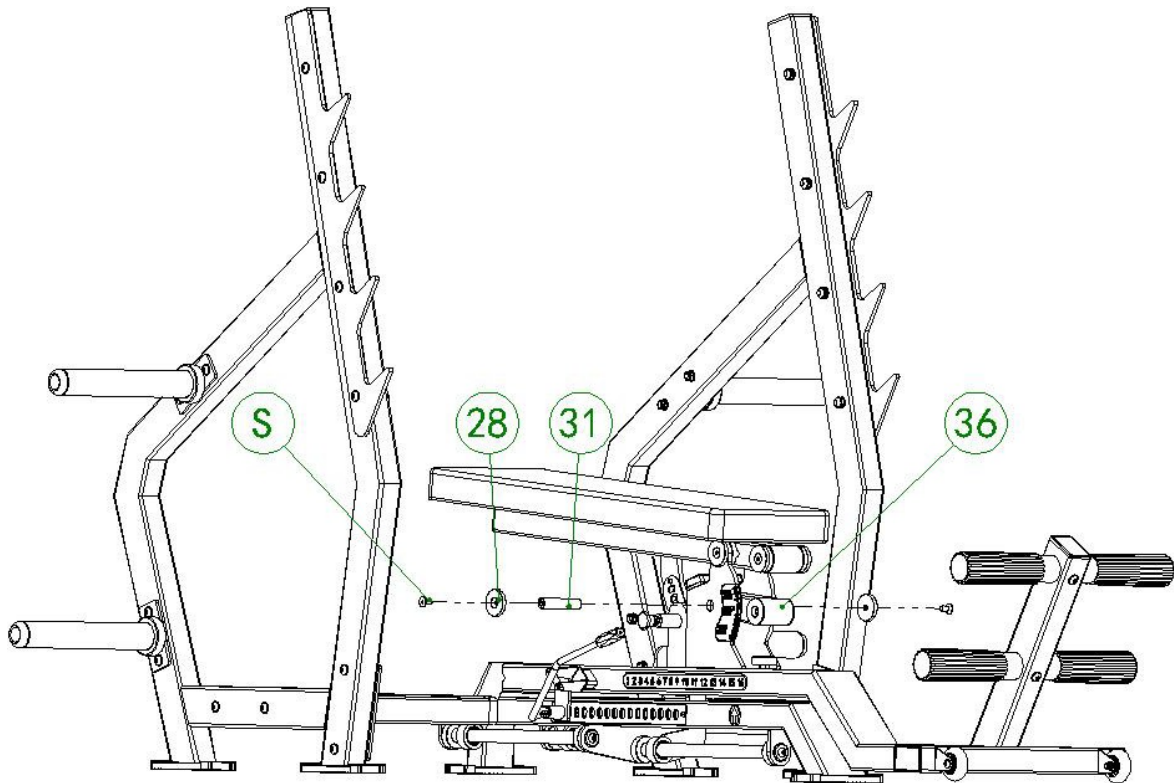
NO.30 backrest group*1

Step	Item No.	Name	Quantity	Item No.	Name	Quantity
	NO.32	0007 back cushion	1	E	M5*12 round head screw	2
	NO.33	curved decorative panel	1	J	Φ8 gasket	4
	NO.34	2013 Polypropylene spacer	4	T	M8*25 round head screw	4
	NO.35	6004-Z1 bearing	4			



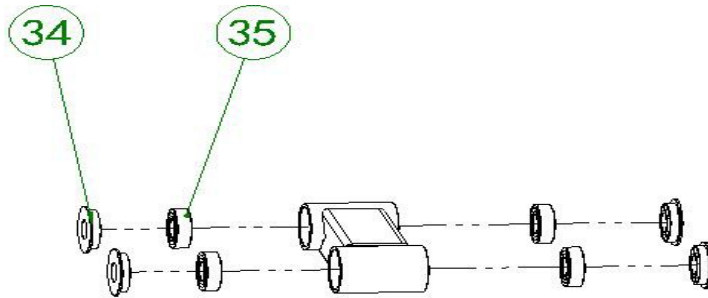
Assembly steps

Step	Item No.	Name	Quantity	Item No.	Name	Quantity
6	NO.28	2004 aluminum alloy flat end cap	2	NO.36	0700 linkage group	1
	NO.31	2004 Galvanized shaft	1	S	M10*20 flat countersunk head screw	2



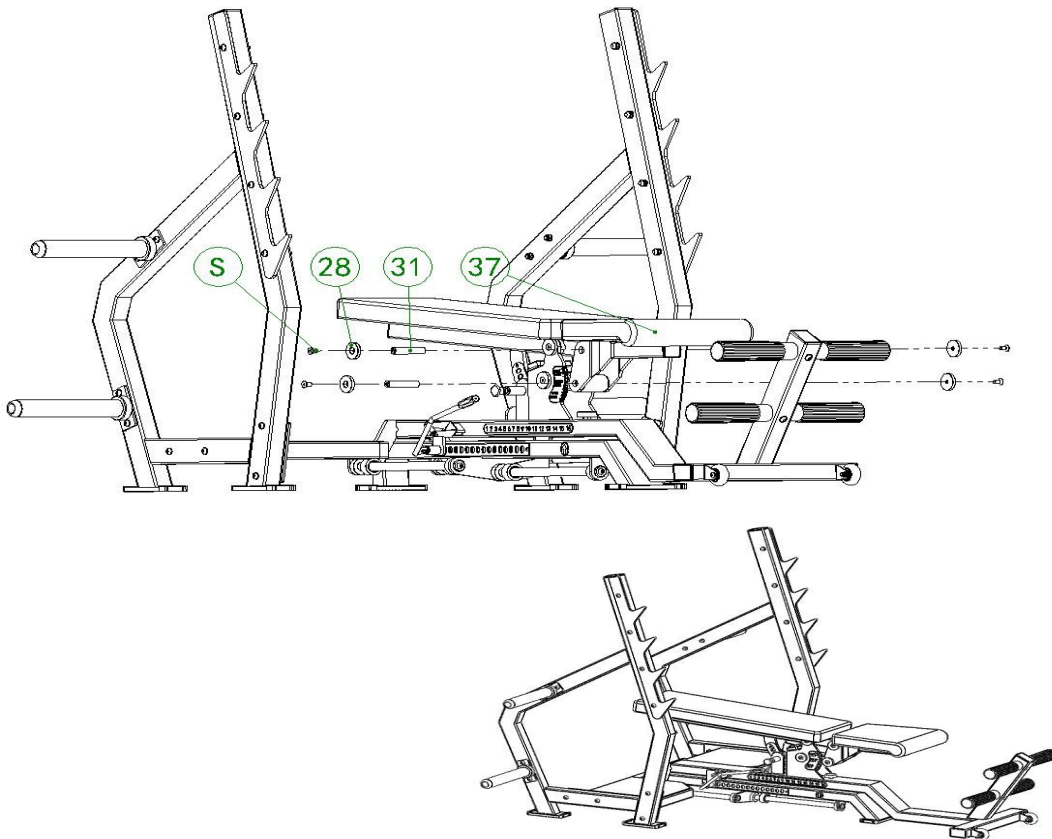
NO.36 linkage group*1

Step	Item No.	Name	Quantity	Item No.	Name	Quantity
	NO.34	2013 Polypropylene spacer	4			
	NO.35	6004-Z1 bearing	4			



Assembly steps

Step	Item No.	Name	Quantity	Item No.	Name	Quantity
7	NO.28	2004 aluminum alloy flat end cap	4	S	M10*20 flat countersunk head screw	4
	NO.31	2004 Galvanized shaft	2			
	NO.37	0200 cushion set	1			



NO.37 cushion set

Step	Item No.	Name	Quantity	Item No.	Name	Quantity
	39	Square tube plug 50*50	2	J	Φ8 gasket	4
	40	Cushion	1	T	M8*25 round head	4

